

INSTRUCTION MANUAL

Micro-computer based Temperature Indicating Controller FCL-100

No.FCL11E3 2000.11

To prevent accidents arising from the use of this controller, please ensure the operator using it receives this manual.



Warning

Turn the power supply to the instrument OFF before wiring or checking.
Working or touching the terminal with the power switched ON may result in Electric Shock, which can cause severe injury or death.

1. Model names

1.1 FCL-130

F C L - 1 3 0 - <input type="checkbox"/> E <input type="checkbox"/> <input type="checkbox"/> <input type="checkbox"/> <input type="checkbox"/> <input type="checkbox"/> <input type="checkbox"/> <input type="checkbox"/> <input type="checkbox"/> <input type="checkbox"/> <input type="checkbox"/>				FCL-100 (W48 x H24 x D98.5mm)	
Temperature alarm	0	<input type="checkbox"/>	<input type="checkbox"/>	<input type="checkbox"/>	No alarm action
Control output	R	<input type="checkbox"/>	<input type="checkbox"/>	<input type="checkbox"/>	Relay contact
	S	<input type="checkbox"/>	<input type="checkbox"/>	<input type="checkbox"/>	Non-contact voltage (for SSR drive)
	A	<input type="checkbox"/>	<input type="checkbox"/>	<input type="checkbox"/>	Current (4 to 20mAdc)
Input	E	<input type="checkbox"/>	<input type="checkbox"/>	<input type="checkbox"/>	TC multi-range input, or TC K type only
Option	TC	<input type="checkbox"/>	<input type="checkbox"/>	<input type="checkbox"/>	Terminal cover
	BK	<input type="checkbox"/>	<input type="checkbox"/>	<input type="checkbox"/>	Color, black
Range		<input type="checkbox"/>	<input type="checkbox"/>	<input type="checkbox"/>	The range designation is required for TC (thermocouple) K type only. (Changeable by the key operation.)
		<input type="checkbox"/>	<input type="checkbox"/>	<input type="checkbox"/>	
		<input type="checkbox"/>	<input type="checkbox"/>	<input type="checkbox"/>	
		<input type="checkbox"/>	<input type="checkbox"/>	<input type="checkbox"/>	

Temperature alarm action is not equipped for the FCL-130 type.

There are 2 input types for the FCL-130; TC (thermocouple) multi-range input and TC K type only.

The options applicable to the FCL-130 are [TC] and [BK].

When ordering:

Choose a type from the table above with alphanumeric characters.

Enter a rated scale (only for the TC K type) and supply voltage using a comma (,).

1.2 FCL-13A

F C L - 1 3 A - <input type="checkbox"/> <input type="checkbox"/> <input type="checkbox"/> <input type="checkbox"/> <input type="checkbox"/> <input type="checkbox"/> <input type="checkbox"/> <input type="checkbox"/> <input type="checkbox"/> <input type="checkbox"/> <input type="checkbox"/>				FCL-13A (W48 x H24 x D98.5mm)	
Temperature alarm	A	<input type="checkbox"/>	<input type="checkbox"/>	<input type="checkbox"/>	Alarm action applied
Control output	R	<input type="checkbox"/>	<input type="checkbox"/>	<input type="checkbox"/>	Relay contact
	S	<input type="checkbox"/>	<input type="checkbox"/>	<input type="checkbox"/>	Non-contact voltage (for SSR drive)
	A	<input type="checkbox"/>	<input type="checkbox"/>	<input type="checkbox"/>	Current (4 to 20mAdc)
Input	M	<input type="checkbox"/>	<input type="checkbox"/>	<input type="checkbox"/>	Multi-range input
	E	<input type="checkbox"/>	<input type="checkbox"/>	<input type="checkbox"/>	TC K type only
Option	C5	<input type="checkbox"/>	<input type="checkbox"/>	<input type="checkbox"/>	Serial communication
	W(5A)	<input type="checkbox"/>	<input type="checkbox"/>	<input type="checkbox"/>	Heater burnout alarm
	W(10A)	<input type="checkbox"/>	<input type="checkbox"/>	<input type="checkbox"/>	
	W(20A)	<input type="checkbox"/>	<input type="checkbox"/>	<input type="checkbox"/>	
	W(50A)	<input type="checkbox"/>	<input type="checkbox"/>	<input type="checkbox"/>	
	SM	<input type="checkbox"/>	<input type="checkbox"/>	<input type="checkbox"/>	Setting value memory (external selection)
	TC	<input type="checkbox"/>	<input type="checkbox"/>	<input type="checkbox"/>	Terminal cover
BK	<input type="checkbox"/>	<input type="checkbox"/>	<input type="checkbox"/>	Color, black	
Range		<input type="checkbox"/>	<input type="checkbox"/>	<input type="checkbox"/>	The range designation is required for TC (thermocouple) K type only. (Changeable by the key operation.)
		<input type="checkbox"/>	<input type="checkbox"/>	<input type="checkbox"/>	
		<input type="checkbox"/>	<input type="checkbox"/>	<input type="checkbox"/>	
		<input type="checkbox"/>	<input type="checkbox"/>	<input type="checkbox"/>	

There are 2 input types for the FCL-13A; Multi-range input and TC K type only.

When the input type is TC K type only, designate a range when ordering.

The options [C5], [W] and [SM] cannot be applied together. (Only one option can be applied.)

When ordering:

Choose a type from the table above with alphanumeric characters.

Enter a rated scale (only for TC K type) and supply voltage using comma (,).

1.3 How to indicate the model name plate

Model name plates are put on the case and the bottom side of the internal assembly.

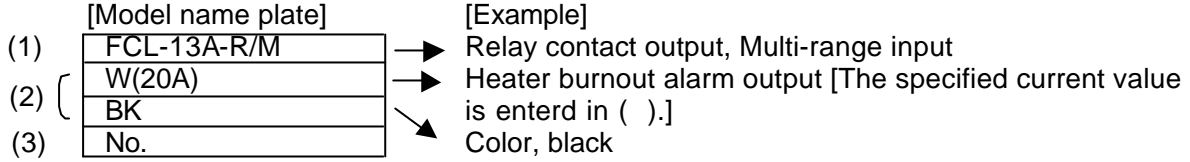

(1): Model name

(2): Option codes

(3): Instrument number (Indicated only on the internal assembly)

2. Name and functions of the section

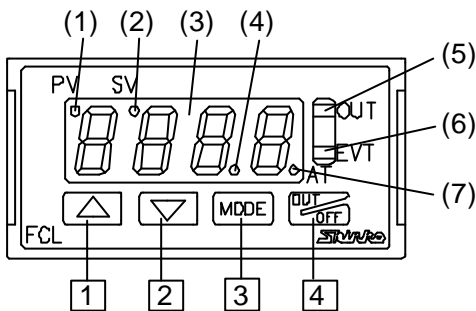

- 1 Increase key : Increases the numeric value.
- 2 Decrease key : Decreases the numeric value.
- 3 MODE key : Selects the setting mode.
- 4 OUT/OFF key : Turns the control output ON or OFF.

- (1) PV indicator : The red LED lights up while Process variable is being indicated on the PV/SV display.
- (2) SV indicator : The red LED lights up while Setting value is being indicated on the PV/SV display. It blinks while being controlled with the main setting 2.
- (3) PV/SV display : Indicates the process variable, setting value and characters with red LED.
- (4) Decimal point indicator : The red LED lights up when decimal point is applied to the setting value. It blinks when Manipulating value (MV) is being displayed.
- (5) Control output indicator : The green LED lights up when the control output is ON.
- (6) Event output indicator : The red LED lights up when the Temperature alarm, Loop break alarm or Heater burnout alarm is ON.
- (7) Auto-tuning action indicator : The red LED blinks while the Auto-tuning or Auto-reset is being performed.

3. Operation

PV/SV display indicates the characters of the sensor type and temperature unit for approx. 2 seconds after the power is turned on. During this time, all outputs and the LED indicators are in their off status. (Refer to table 3.1-1 and 3.1-2.)

After that, actual temperature or the main setting value is indicated, and control starts.

(If PV display is selected in PV/SV display selection, the actual temperature will be indicated.

If SV display is selected, the main setting value will be indicated.)

[Table 3.1-1]

Input	PV/SV display	
	°C	°F
K	E C	E F
J	J C	J F
PL-II	PL2C	PL2F
N	n C	n F
E	E C	E F
Pt100 (With decimal point)	Pt C	Pt F
JPt100 (With decimal point)	JPt C	JPt F
Pt100	Pt C	Pt F
JPt100	JPt C	JPt F

[Table 3.1-2]

Thermocouple K input only	PV/SV display	
	°C	°F
0 to 400°C	E 4C	E 4F
0 to 750°F	E 4C	E 4F
0.0 to 400.0°C	E 4C	E 4F
0.0 to 750.0°F	E 4C	E 4F

3.2 Main setting mode

Character	Name, Description, Setting range	Initial
5	Main setting 1 <ul style="list-style-type: none"> Sets Main setting value 1 of the main control. Main setting low limit value to Main setting high limit value 	0°C (F)
52	Main setting 2 <ul style="list-style-type: none"> Sets Main setting value 2 of the main control. This setting item is available only when the option [SM] is applied. Main setting low limit value to Main setting high limit value 	0°C (F)

3.3 Sub setting mode

Character	Name, Description, Setting range	Initial
RT r5f	Auto-tuning Perform/Cancel, or Auto-reset Perform <ul style="list-style-type: none"> Designates auto-tuning performance or cancellation, or auto-reset performance. Auto-reset will be canceled automatically in approx. 4 minutes. 	Cancel
P	Proportional band value setting <ul style="list-style-type: none"> Sets the proportional band of control output. Setting the value to 0 or 0.0, control output acts ON/OFF. 0 (0.0) to rated scale maximum value 	10°C (20°F)
I	Integral time setting <ul style="list-style-type: none"> Sets the integral time of control output. Setting the value to 0 disables the function. With PD action (I=0), auto-reset can be performed. 0 to 3600 seconds 	200s
D	Derivative time setting <ul style="list-style-type: none"> Sets the derivative time of control output. Setting the value to 0 disables the function. 0 to 3600 seconds 	50s
C	Proportional cycle setting <ul style="list-style-type: none"> Sets the proportional cycle value. This setting item is not available when ON/OFF action or current output type is selected. 1 to 120 seconds 	R/ <input type="checkbox"/> 30s S/ <input type="checkbox"/> 3s
R	Temperature alarm setting <ul style="list-style-type: none"> Sets the action point of the temperature alarm output. This setting item is not available for the FCL-130. This setting item is not available if no alarm action is selected in Temperature alarm action selection. This setting item is available only when the "Temperature alarm output function" is selected in "Event output function selection". Refer to the Table 3.3-1. 	0°C(F)
H	Heater burnout alarm setting <ul style="list-style-type: none"> Sets the current value of Heater burnout alarm. This setting item is available only when the option [W] is applied. This setting item is available only when the "Heater burnout alarm" is selected in "Event output function selection". Self-holding is not available to the alarm output. In the case of 5A, 0.0 to 5.0A In the case of 10A, 0.0 to 10.0A In the case of 20A, 0.0 to 20.0A In the case of 50A, 0.0 to 50.0A 	0.0A

<i>LPT</i>	Loop break alarm action time setting <ul style="list-style-type: none"> • Sets the time it takes to assess the Loop break alarm. • This setting item is not available for the FCL-130. • This setting item is available only when the “Loop break alarm” is selected in “Event output function selection”. • 0 to 200 minutes 	0 min.
<i>LPK</i>	Loop break alarm action span setting <ul style="list-style-type: none"> • Sets the span to assess the Loop break alarm. • This setting item is not available for the FCL-130. • This setting item is available only when the “Loop break alarm” is selected in “Event output function selection”. • 0 to 150°C (F), or 0.0 to 150.0°C (F) 	0°C (F)

[Table 3.3-1]

Alarm action type	Setting range	Setting range (with decimal point)
High limit alarm	-Input range span to input range span	-199.9 to input range span
Low limit alarm	-Input range span to input range span	-199.9 to input range span
High/Low limits alarm	0 to input range span	0.0 to input range span
High/Low limit range alarm	0 to input range span	0.0 to input range span
Process high alarm	Input range minimum to input range maximum	Input range minimum to input range maximum
Process low alarm	Input range minimum to input range maximum	Input range minimum to input range maximum
High limit alarm w/standby	-Input range span to input range span	-199.9 to input range span
Low limit alarm w/standby	-Input range span to input range span	-199.9 to input range span
High/Low limits w/standby	0 to input range span	0.0 to input range span
Hi/Lo limit range w/standby	0 to input range span	0.0 to input range span
Process high alarm with standby	Input range minimum to input range maximum	Input range minimum to input range maximum
Process low alarm with standby	Input range minimum to input range maximum	Input range minimum to input range maximum

3.4 Auxiliary function setting mode 1

Character	Name, Description, Setting range	Initial
<i>PB</i>	PV/SV display change <ul style="list-style-type: none"> • Changes the display PV (<i>PB</i>) or SV (<i>SB</i>). 	PV display
<i>Loc</i>	Setting value lock designation <ul style="list-style-type: none"> • Locks the setting value to prevent error. The setting item to be locked depends on the designation. • PID auto-tuning or auto-reset will not function if Lock 1 or Lock 2 is designated. • ---- (Unlock): All setting values can be changed. • <i>Lc1</i> (Lock 1): None of the setting values can be changed. • <i>Lc2</i> (Lock 2): Only main setting value is changeable. • <i>Lc3</i> (Lock 3): All setting values can be changed, however, they revert to their former values after the power is turned off because they are not stored in the non-volatile memory. Since this function has no relation to the memory life, it is well suited for the PC-900. (With the option [SVTC: Setting value digital transmission]). 	Unlock
<i>SH</i>	Main setting value high limit setting <ul style="list-style-type: none"> • Sets the high limit value of main setting. • Main setting low limit to input range maximum 	Multi-range input (TC multi-range input) : 1370°C K type only: 400°C
<i>SL</i>	Main setting value low limit setting <ul style="list-style-type: none"> • Sets the low limit value of main setting. • Input range minimum to main setting high limit 	0°C

40	Sensor correction setting <ul style="list-style-type: none"> • Sets sensor correction value. • -100.0 to 100.0°C (°F) 	0.0°C (°F)
c̄n̄n̄o	Instrument number setting <ul style="list-style-type: none"> • Sets the Instrument number individually to each instrument when communicating by connecting multiple instruments in serial communication. • This setting item is available only when the option [C5] is applied. • 0 to 95 	0
c̄n̄4P	Transfer rate setting <ul style="list-style-type: none"> • Selects the communication transfer rate to meet the rate of the host computer. • This setting item is available only when the option [C5] is applied. • 2400bps: 24 • 4800bps: 48 • 9600bps: 96 • 19200bps: 192 	9600bps

3.5 Auxiliary function setting mode 2

Character	Name, Description, Setting range	Initial				
4En	Sensor selection <ul style="list-style-type: none"> • With multi-range input type, input type and unit (°C or °F) can be chosen from 5 types of thermocouple and 4 types of RTD. • With TC multi-range input type, input type and unit (°C or °F) can be chosen from 5 types of thermocouple. • With thermocouple K type only, 2 types of scale range and unit (°C or °F) are selectable. 	K				
	<table border="0"> <tr> <td style="vertical-align: top;"> Multi-range input type K 0 to 1370°C : E C J 0 to 1000°C : J C PL-II 0 to 1390°C : PL2C N 0 to 1300°C : n C E 0 to 800°C : E C Pt100 -199.9 to 850.0°C : Pt C JPt100 -199.9 to 500.0°C : JPt C Pt100 -200 to 850°C : Pt C JPt100 -200 to 500°C : JPt C K 0 to 2500°F : E F J 0 to 1800°F : J F PL-II 0 to 2500°F : PL2F N 0 to 2300°F : n F E 0 to 1500°F : E F Pt100 -199.9 to 999.9°F : Pt F JPt100 -199.9 to 900.0°F : JPt F Pt100 -300 to 1500°F : Pt F JPt100 -300 to 900°F : JPt F </td> <td style="vertical-align: top;"> Thermocouple multi-range input type K 0 to 1370°C : E C J 0 to 1000°C : J C PL-II 0 to 1390°C : PL2C N 0 to 1300°C : n C E 0 to 800°C : E C K 0 to 2500°F : E F J 0 to 1800°F : J F PL-II 0 to 2500°F : PL2F N 0 to 2300°F : n F E 0 to 1500°F : E F </td> </tr> <tr> <td></td> <td> Thermocouple K type only K 0 to 400°C : E 4C K 0.0 to 400.0°C : E 4C K 0 to 750°F : E 4F K 0.0 to 750.0°F : E 4F </td> </tr> </table>	Multi-range input type K 0 to 1370°C : E C J 0 to 1000°C : J C PL-II 0 to 1390°C : PL2C N 0 to 1300°C : n C E 0 to 800°C : E C Pt100 -199.9 to 850.0°C : Pt C JPt100 -199.9 to 500.0°C : JPt C Pt100 -200 to 850°C : Pt C JPt100 -200 to 500°C : JPt C K 0 to 2500°F : E F J 0 to 1800°F : J F PL-II 0 to 2500°F : PL2F N 0 to 2300°F : n F E 0 to 1500°F : E F Pt100 -199.9 to 999.9°F : Pt F JPt100 -199.9 to 900.0°F : JPt F Pt100 -300 to 1500°F : Pt F JPt100 -300 to 900°F : JPt F	Thermocouple multi-range input type K 0 to 1370°C : E C J 0 to 1000°C : J C PL-II 0 to 1390°C : PL2C N 0 to 1300°C : n C E 0 to 800°C : E C K 0 to 2500°F : E F J 0 to 1800°F : J F PL-II 0 to 2500°F : PL2F N 0 to 2300°F : n F E 0 to 1500°F : E F		Thermocouple K type only K 0 to 400°C : E 4C K 0.0 to 400.0°C : E 4C K 0 to 750°F : E 4F K 0.0 to 750.0°F : E 4F	
Multi-range input type K 0 to 1370°C : E C J 0 to 1000°C : J C PL-II 0 to 1390°C : PL2C N 0 to 1300°C : n C E 0 to 800°C : E C Pt100 -199.9 to 850.0°C : Pt C JPt100 -199.9 to 500.0°C : JPt C Pt100 -200 to 850°C : Pt C JPt100 -200 to 500°C : JPt C K 0 to 2500°F : E F J 0 to 1800°F : J F PL-II 0 to 2500°F : PL2F N 0 to 2300°F : n F E 0 to 1500°F : E F Pt100 -199.9 to 999.9°F : Pt F JPt100 -199.9 to 900.0°F : JPt F Pt100 -300 to 1500°F : Pt F JPt100 -300 to 900°F : JPt F	Thermocouple multi-range input type K 0 to 1370°C : E C J 0 to 1000°C : J C PL-II 0 to 1390°C : PL2C N 0 to 1300°C : n C E 0 to 800°C : E C K 0 to 2500°F : E F J 0 to 1800°F : J F PL-II 0 to 2500°F : PL2F N 0 to 2300°F : n F E 0 to 1500°F : E F					
	Thermocouple K type only K 0 to 400°C : E 4C K 0.0 to 400.0°C : E 4C K 0 to 750°F : E 4F K 0.0 to 750.0°F : E 4F					
FILF	PV filter time constant setting <ul style="list-style-type: none"> • Sets PV filter time constant value. • If the value is set too large, it affects control result due to the delay of response. • 0.0 to 10.0 seconds. 	0.0s				
oLH	Output high limit setting <ul style="list-style-type: none"> • Sets output high limit value. • This setting item is not available for the ON/OFF action. • -5 to 105% (Setting greater than 100% is effective to the type Current output only.) 	100%				

oLL	Output low limit setting <ul style="list-style-type: none"> • Sets output low limit value. • This setting item is not available for the ON/OFF action. • -5 to 105% (Setting less than 0% is effective to the type Current output only.) 	0%
HYS	Output ON/OFF action hysteresis setting <ul style="list-style-type: none"> • Sets the ON/OFF action hysteresis of control output. • This setting item is available only for the ON/OFF action. • 0.1 to 100.0°C 	1.0°C
EBnF	Event output function selection <ul style="list-style-type: none"> • One of the functions is selectable from Temperature alarm, Loop break alarm or Heater burnout alarm. • This setting item is not available for the FCL-130. • Heater burnout alarm can be selected only when option [W] is applied. • Temperature alarm output : RL\bar{n} • Loop break alarm output : LP • Heater burnout alarm output (option) : Hb 	RL \bar{n}
RL_F	Temperature alarm action selection <ul style="list-style-type: none"> • Selects temperature alarm action. • No alarm : ---- • High limit alarm : H • High limit alarm w/standby : H 0 • Low limit alarm : L • Low limit alarm w/standby : L 0 • High/Low limits alarm : HL • High/Low limits alarm w/standby : HL 0 • High/Low limit range alarm : 01 d • High/Low limit range alarm w/standby : 01 d 0 • Process high alarm : RH • Process high alarm w/standby : RH 0 • Process low alarm : rRH • Process low alarm w/standby : rRH 0 	No alarm
RL_E	Temperature alarm energized/deenergized selection <ul style="list-style-type: none"> • Sets the temperature alarm output as energized or deenergized. • This setting item is not available for the FCL-130. • This setting item is not available if Temperature alarm output is not selected in Event output function selection, nor if No alarm is selected in Temperature alarm action selection. • Energized : n0\bar{n} • Deenergized: rE\bar{E} 	Energized
RLHY	Temperature alarm hysteresis setting <ul style="list-style-type: none"> • Sets hysteresis value for temperature alarm. • This setting item is not available for the FCL-130. • This setting item is not available if Temperature alarm output is not selected in Event output function selection, nor if No alarm is selected in Temperature alarm action selection. • 0.1 to 100.0°C (F) 	1.0°C (F)
RLdY	Temperature alarm delayed timer setting <ul style="list-style-type: none"> • Sets the action delayed timer for temperature alarm. Alarm output works past the setting time after the input value reaches the alarm output range. • This setting item is not available for the FCL-130. • This setting item is not available if Temperature alarm output is not selected in Event output function selection, nor if No alarm action is selected in Temperature alarm action selection. • 0 to 9999 seconds 	0s

<i>rRFU</i>	Main setting value rising rate setting <ul style="list-style-type: none"> • Sets the rising rate of main setting value. (Rising value per minute) • 0 to 9999°C/min. (°F/min.) With decimal point, 0.0 to 999.9°C/min. (°F/min.) 	0°C/min.
<i>rRFd</i>	Main setting value falling rate setting <ul style="list-style-type: none"> • Sets the falling rate of main setting value. (Falling value per minute) • 0 to 9999°C/min. (°F/min.) With decimal point, 0.0 to 999.9°C/min. (°F/min.) 	0°C/min.
<i>cnf</i>	Output Direct/Reverse change <ul style="list-style-type: none"> • Changes the output action Reverse (Heating) or Direct (Cooling). • Reverse (Heating) action: <i>HEAT</i> Direct (Cooling) action : <i>COOL</i> 	Reverse (Heating) action
<i>RF_b</i>	Auto-tuning bias setting <ul style="list-style-type: none"> • Sets PID auto-tuning bias value. • 0 to 50°C (0 to 100°F) With decimal point, 0.0 to 50.0°C (0.0 to 100.0°F) 	20°C (40°F)

Sensor correction function

Corrects the input value from the sensor. When a sensor cannot be set at a location where control is desired, the sensor measuring temperature may deviate from the temperature in the controlled location. When controlling with plural controllers, the accuracy of sensors affects the control.

Therefore, sometimes the measuring temperature (input value) does not concur with the same setting value. In such a case, the control can be set with the desired temperature by shifting the input value of sensors.

Loop break alarm

After the manipulating value has reached 100% or output high limit value, if the process variable (PV) has not risen at least as high as the span value by the time it takes to assess the loop break alarm, the alarm will be activated.

After the manipulating value has reached 0% or output low limit value, if the process variable (PV) has not fallen at least as low as the value of the span within the time it takes to assess the loop break alarm, the alarm will also be activated.

When the control action is Direct (Cooling), the alarm acts conversely.

Energized/Deenergized

When the status of temperature alarm action is selected energized, event output (between terminal 11 and 12) is conducted (ON) status while the event output indicator is lit. Event output is not conducted (OFF) status while the event output indicator is not lit.

When the status of temperature alarm action is selected deenergized, event output (between terminal 11 and 12) is not conducted (OFF) status while the event output indicator is lit. Event output is conducted (ON) status while the event output indicator is not lit.

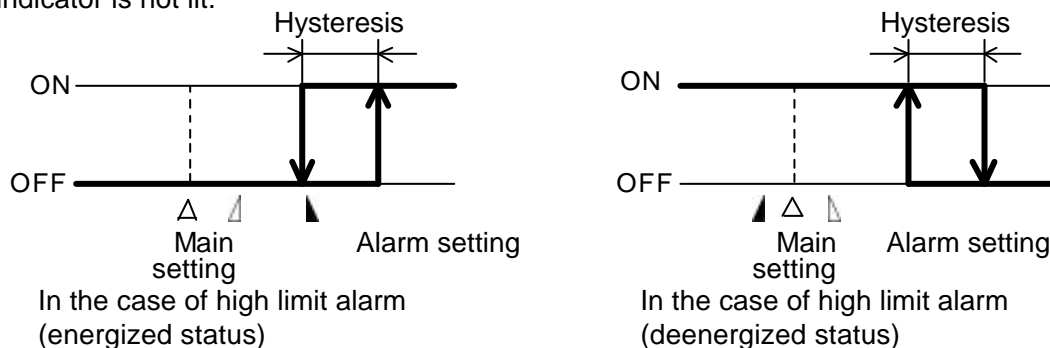



Setting value memory function

If the option SM is applied, the setting value memory number can be selected by external operation. (However, selectable setting value memory number is No. 2 only.)



To select the setting value memory number 2, connect the terminals between 8 and 9.

Memory number cannot be changed during setting mode and PID auto-tuning.

3.6 Control output OFF function

Character	Name, Descriptions
oFF	<p>Control output OFF function</p> <ul style="list-style-type: none"> This is the function to switch the control output OFF even if power is supplied to the instrument. The function is used when required to halt the control action or the FCL-100 is not used in multiple controllers. "oFF" is indicated on the PV/SV display. This function can be selected from any mode or any setting item by pressing the  key for approx. 1 second. Once the function is working, it cannot be released even if the power to the instrument is turned OFF and ON again. To cancel the function, press the  key again for approx. 1 second.

3.7 Output manipulating value display

Character	Name, Descriptions
	<p>Output manipulating value display</p> <ul style="list-style-type: none"> In the PV/SV display mode, press the  key for approx. 3 seconds. The display will be changed to main setting mode during the process, however, keep pressing until the output manipulating value is displayed. (Manipulating value is indicated on the PV/SV display blinking the decimal point.) If the  key is pressed again, the mode will revert to the PV/SV display.

4. Running

After the completion of the mounting to the control panel and wiring connections, start running in the following manner.

(1) Turn the power supplied to the FCL-100 ON

For approx. 2 seconds after the power is switched ON, the type of sensor is indicated on the PV/SV display. (Refer to table 3.1-1 and 3.1-2.)

During this time, all outputs and LED indicators are in their OFF status.

After that, the PV/SV display indicates actual temperature.

If SV display is selected in PV/SV display change, the setting value will be indicated.

In the status the Control output OFF function is working, it indicates "oFF" on the PV/SV display.

(2) Input the setting value

Referring to Chapter 3. Operation, input each setting value.

(3) Turn the load circuit power ON.

Starts the control action so as to keep the controlled object at the main setting value.

5. Other functions

(1) Input burnout

[Upscale]

When the thermocouple or RTD is burnt out or the input value rises to the [Rated scale maximum value + 50°C (100°F)] or greater, the control output is turned off, and [_ _ _ _] blinks on the PV/SV display.

However, when the rated scale maximum value is 999.9, if the input value exceeds 999.9,

[_ _ _ _] blinks on the PV/SV display, and the control is performed to 999.9 + 1% of rated scale span.

[Downscale]

In the case of thermocouple input, if the input value falls to -50°C (-100°F) or less, the control output is turned off, and [- - - -] blinks on the PV/SV display.

In the case of RTD input, if the input value falls to the [Rated scale minimum value - 1% of rated scale span] or less, the control output is turned off, and [- - - -] blinks on the PV/SV display.

However, when the rated scale minimum value is -199.9, if the input value falls to -199.9 or less, [- - - -] blinks on the PV/SV display, and the control is performed to -199.9 - 1% of rated scale span.

Even in SV display mode, the indication of [_ _ _ _] in upscale and of [- - - -] in downscale have priority over all displays.

(2) Self-diagnostic function

The CPU is monitored by a watchdog timer, and when any abnormal status is found on the CPU, the controller is switched to warm-up status.

(3) Automatic cold junction temperature compensation (thermocouple input type)

Detects the temperature at the connection terminal between thermocouple and instrument, and always keeps it on the same status as when the reference junction is located at 0°C (32°F).

6. Action explanations

6.1 Standard action drawing

Action	Heating (reverse) action	Cooling (direct) action
Control action	<p>Proportional band</p> <p>ON</p> <p>OFF</p> <p>Setting</p>	<p>Proportional band</p> <p>ON</p> <p>OFF</p> <p>Setting</p>
Relay contact output	<p>Cycle action according to deviation</p>	<p>Cycle action according to deviation</p>
Non-contact voltage output	<p>12Vdc</p> <p>12/0Vdc</p> <p>0Vdc</p> <p>Cycle action according to deviation</p>	<p>0Vdc</p> <p>0/12Vdc</p> <p>12Vdc</p> <p>Cycle action according to deviation</p>
Current output	<p>20mA</p> <p>20 to 4mA</p> <p>4mA</p> <p>Changes continuously according to deviation</p>	<p>4mA</p> <p>4 to 20mA</p> <p>20mA</p> <p>Changes continuously according to deviation</p>
Indicator (OUT) Green	<p>Lit</p> <p>Unlit</p>	<p>Unlit</p> <p>Lit</p>

part: Acts ON or OFF.

6.2 ON/OFF action drawing

Action	Heating (reverse) action	Cooling (direct) action
Control action	<p>Hysteresis</p> <p>ON</p> <p>OFF</p> <p>Setting</p>	<p>Hysteresis</p> <p>ON</p> <p>OFF</p> <p>Setting</p>
Relay contact output		
Non-contact voltage output	<p>12Vdc</p> <p>0Vdc</p>	<p>0Vdc</p> <p>12Vdc</p>
Current output	<p>20mA</p> <p>4mA</p>	<p>4mA</p> <p>20mA</p>
Indicator (OUT) Green	<p>Lit</p> <p>Unlit</p>	<p>Unlit</p> <p>Lit</p>

part: Acts ON or OFF.

6.3 Alarm action drawings

	High limit alarm action	Low limit alarm action	High/Low limits alarm action
Alarm action			
Output			
Indicator			
	High/Low limit range alarm action	Process high alarm action	Process low alarm action
Alarm action			
Output			
Indicator			
	High limit alarm with standby	Low limit alarm with standby	High/Low limits alarm with standby
Alarm action			
Output			
Indicator			
	High/Low limit range alarm with standby	Process high alarm with standby	Process low alarm with standby
Alarm action			
Output			
Indicator			

part: Acts ON or OFF.
 part: The standby functions.

6.4 Heater burnout alarm drawing

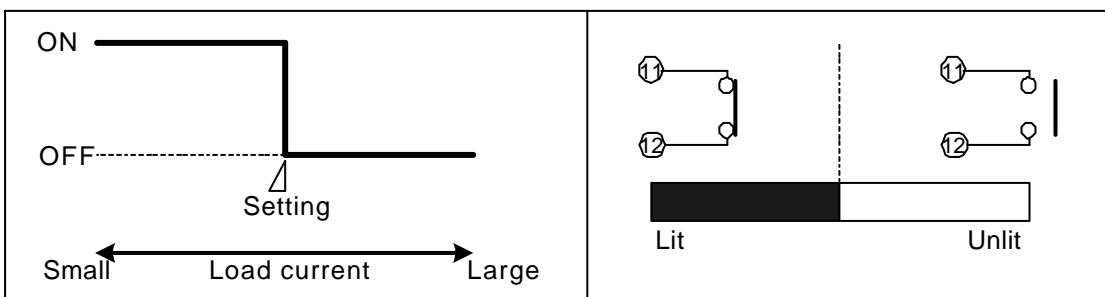

7. PID auto-tuning of the FCL-100

In order to decide each value of P, I, D and ARW automatically, this system forcibly fluctuates the object being controlled.

- **When the difference between setting value and processing temperature is large when the temperature rises.**

Fluctuation is given at the temperature 20°C (°F) lower than the setting value.

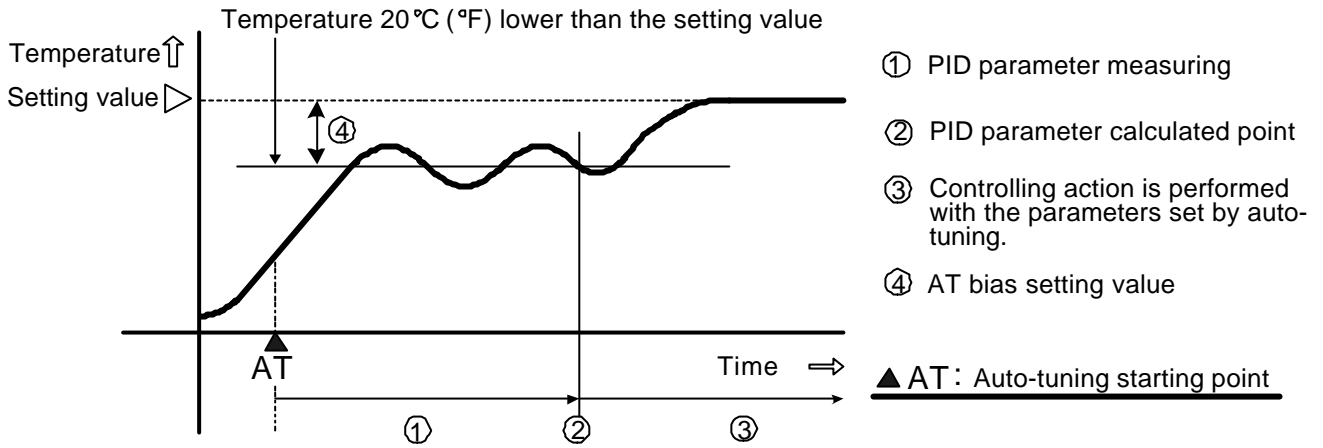

- **When the control is stable**

Fluctuation is given at the setting value.

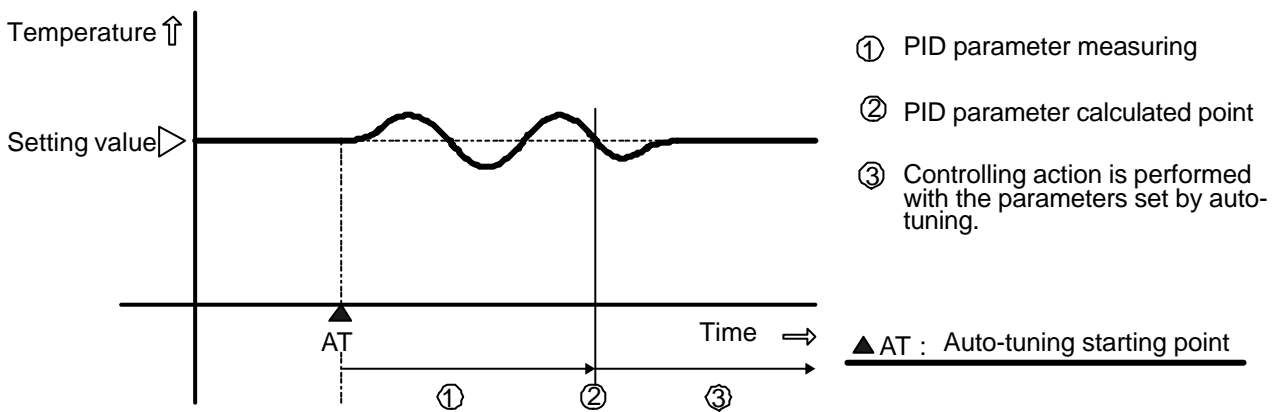

- **When the difference between setting value and processing temperature is large when the temperature falls.**

Fluctuation is given at the temperature 20°C (°F) or higher than the setting value.

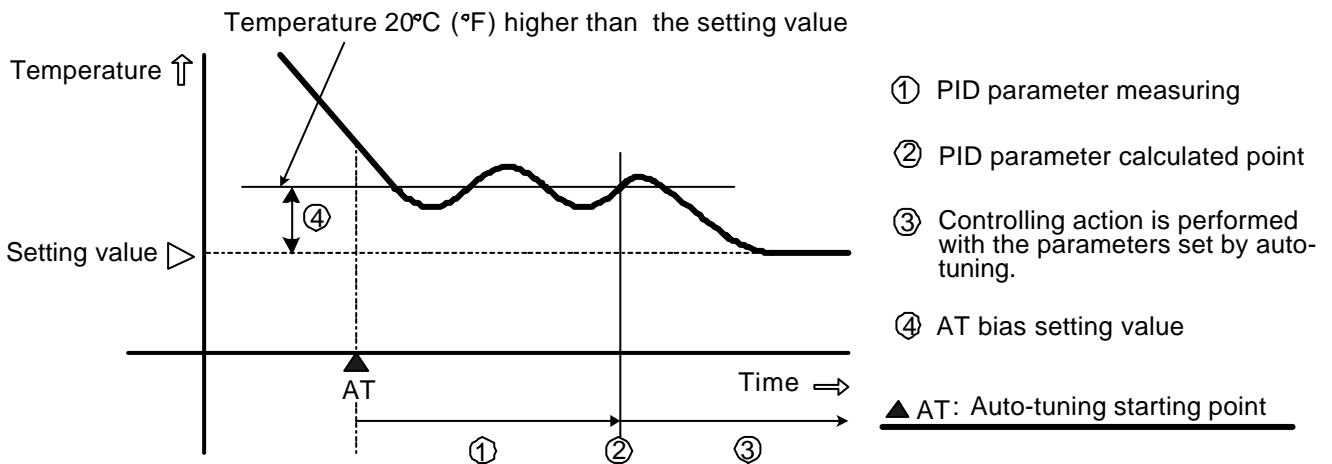

8. Mounting to the control panel

8.1 Site selection

Mount the controller in a place with:

- (1) A minimum of dust, and an absence of corrosive gases.
- (2) No mechanical vibrations or shocks.
- (3) No exposure to direct sunlight, an ambient temperature of 0 to 50°C (32 to 122°F) that does not change suddenly.
- (4) An ambient non-condensing humidity of 35 to 85%RH or less.
- (5) The controller away from large capacity electromagnetic switches or cables through which large current is flowing.
- (6) No water, oil or chemicals or where the vapors of these substances can come into direct contact with the unit.

8.2 External dimension drawing

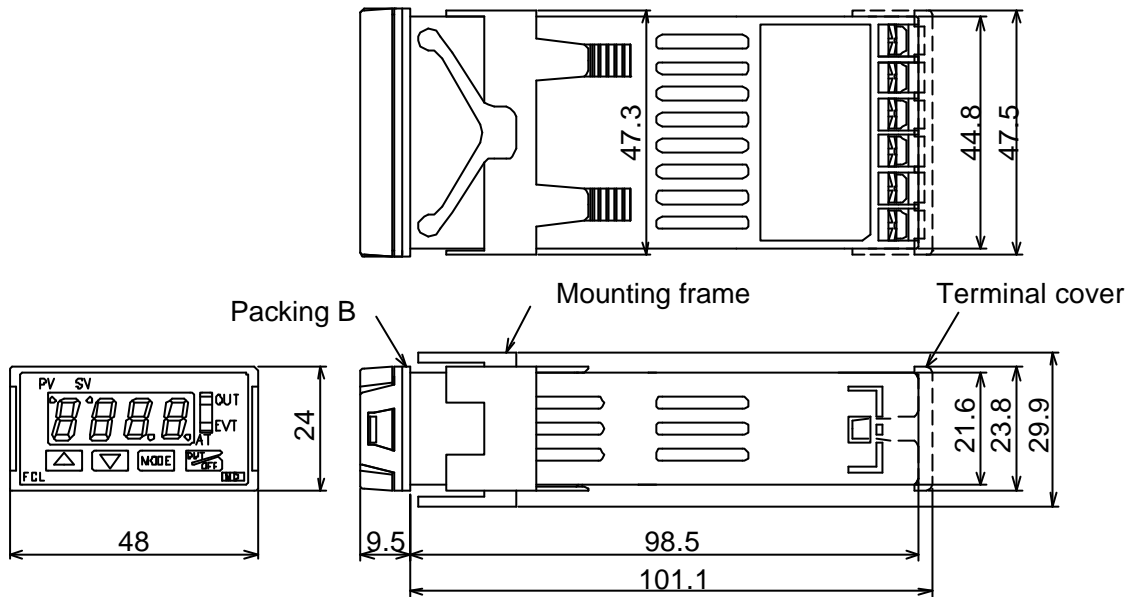

[Fig. 8.2-1]

8.3 Panel cutout drawing

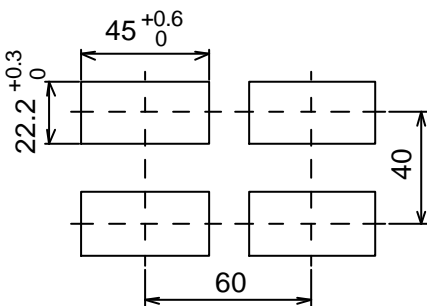

[Fig. 8.3-1]

8.4 CT (current transformer) dimension drawing

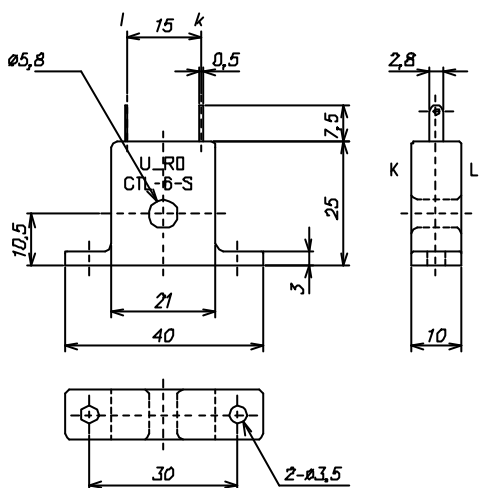

CTL-6-S (5A, 10A, 20A)

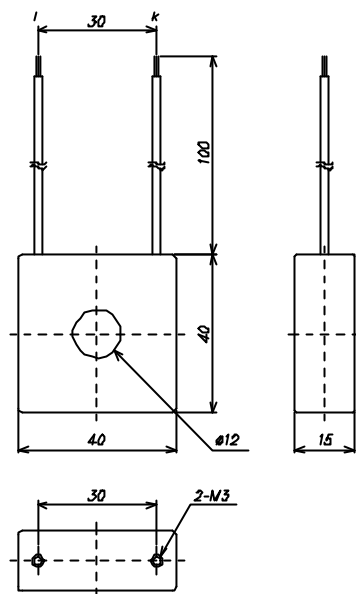

CTL-12-S36-10L1 (50A)

8.5 Mounting

Mounting panel thickness is from 1 to 10mm.
 Insert the FCL-100 from the front of the panel.
 Insert the mounting frame as shown in [Fig. 8.5-1] until the four tips of the frame touch the front panel.

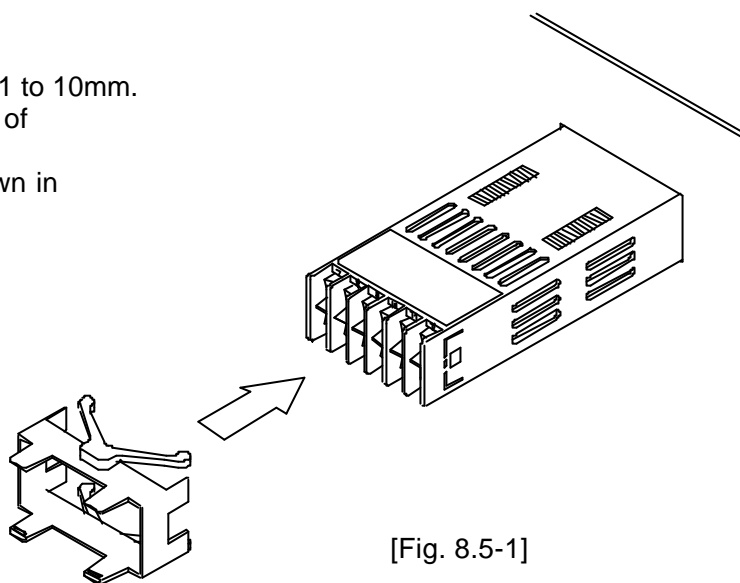

[Fig. 8.5-1]

9. Terminal arrangement

Warning

Turn the power supply to the instrument OFF before wiring or checking.
Working or touching the terminal with the power switched ON may result in an Electric Shock which could cause severe injury or death.

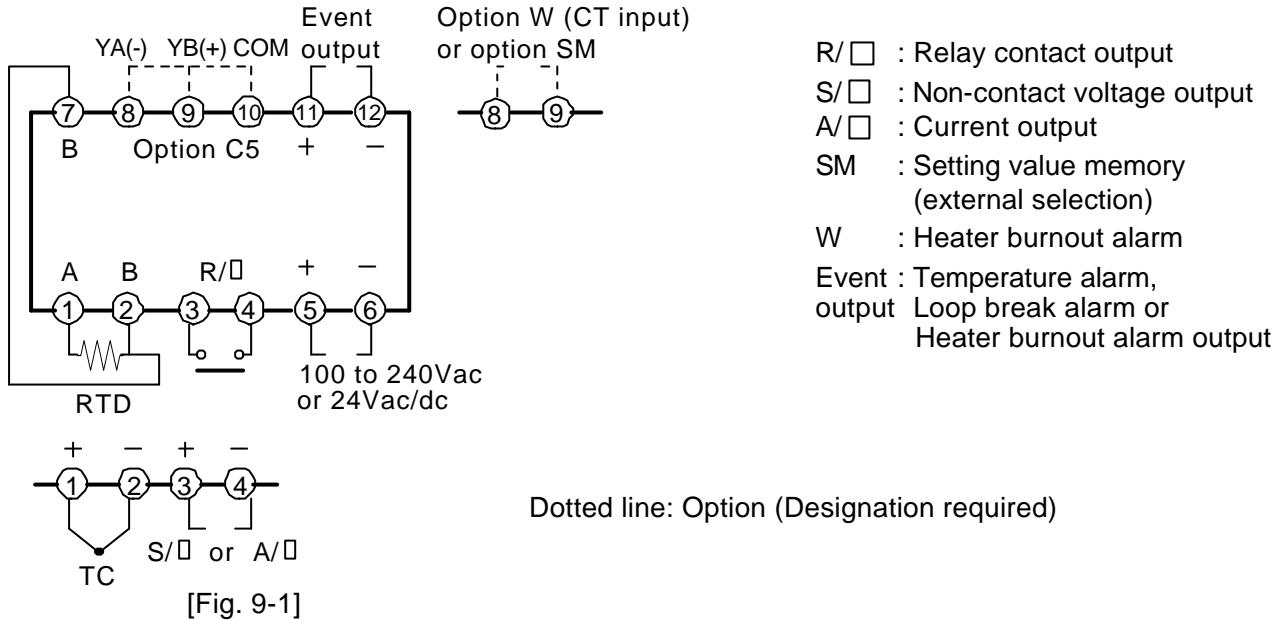

Notices

- Use a thermocouple and compensating lead wire according to the input specifications of this controller.
- Use a 3-wire system of RTD according to the input specifications of this controller.
- This controller has no built-in power switch nor fuse. It is necessary to install them manually (IEC approved, 100Vac 5A, 220Vac 5A) in the circuit near the external controller.
- In the case of 24Vdc, do not confuse the polarity.
- With the relay contact output type, use an external auxiliary electromagnetic switch to protect the built-in relay contact.
- When wiring, keep input wire (Thermocouple, RTD, etc.) away from AC source and load wire to avoid external interference.

● Recommended terminal

Use a solderless terminal with an insulation sleeve that fits to M3 screw as shown below.

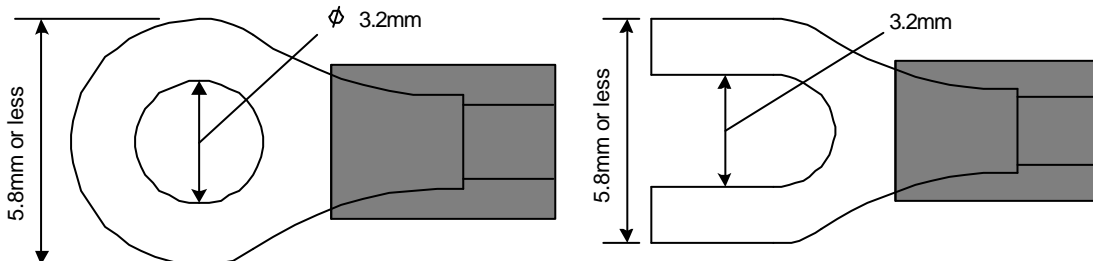

Solderless terminal	Manufacturer	Model name	Tightening torque
Y type	Nichifu Terminal Industries CO.,LTD.	1.25Y-3	0.6N•m Max. 1.0N•m
	Japan Solderless Terminal MFG CO.,LTD.	VD1.25-B3A	
Round type	Nichifu Terminal Industries CO.,LTD.	1.25-3	
	Japan Solderless Terminal MFG CO.,LTD.	V1.25-3	

Option: Heater burnout alarm output

- (1) This alarm is not available for detecting current under phase control.
- (2) Use the current transformer (CT) supplied and pass one lead wire of heater circuit into the hole of the CT.
- (3) When wiring, keep CT wire away from AC source and load wire to avoid external interference.

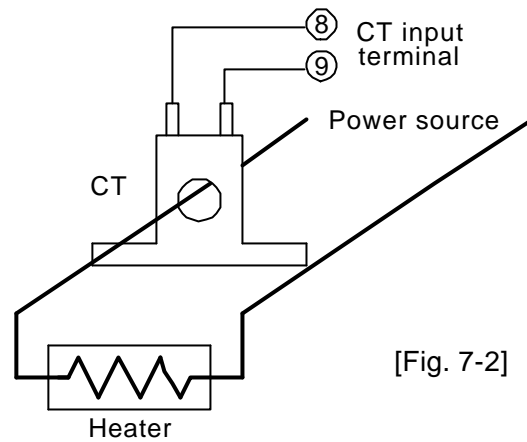

8. Specifications

8.1 Standard specifications

Mounting method : Flush

Setting : Input system by using membrane sheet key

Display

PV/SV display : Red LED display 4 digits, size, 8(H) x 4(W)mm

Accuracy (Setting and indicating)

Thermocouple : Within $\pm 0.3\%$ of input range full scale ± 1 digit, or 2°C (4°F) whichever is greater

RTD : Within $\pm 0.2\%$ of input range full scale ± 1 digit or 1°C (2°F) whichever is greater

Scaling range

In the case of Multi-range input and TC multi-range input type

K : 0 to 1370°C (0 to 2500°F)

J : 0 to 1000°C (0 to 1800°F)

E : 0 to 800°C (0 to 1500°F)

PL-II : 0 to 1390°C (0 to 2500°F)

N : 0 to 1300°C (0 to 2300°F)

*Pt100 : -199.9 to 850.0°C (-199.9 to 999.9°F), -200 to 850°C (-300 to 1500°F)

*JPt100: -199.9 to 500.0°C (-199.9 to 900.0°F), -200 to 500°C (-300 to 900°F)

*: **Pt100 and JPt100 are not available for TC multi-range input type.**

In the case of thermocouple K type only

K : 0 to 400°C (0 to 750°F)

0.0 to 400.0°C (0.0 to 750.0°F)

Input sampling period: 0.25 seconds

Input

Thermocouple : K, J, E, PL-II, N
External resistance, 100Ω or less
When input burnout, Upscale

RTD : Pt100, JPt100 3-wire system
Allowable input lead wire resistance,
 10Ω or less per wire
When input burnout, Upscale

Control output

Relay contact : 1a
Control capacity,
250Vac 3A (resistive load)
250Vac 1A (inductive load $\cos\phi=0.4$)

Non-contact voltage : For SSR drive
 12^{+2}_0Vdc Maximum 40mA (short circuit protected)

Current : 4 to 20mA_{dc}
Load resistance, maximum 500Ω

Supply voltage : 100 to 240Vac, 50/60Hz, 24Vac/dc, 50/60Hz

Allowable voltage fluctuation : In the case of 100 to 240Vac, 85 to 264Vac
In the case of 24Vac/dc, 20 to 28Vac/dc

Temperature alarm output

The alarm action point is set by \pm deviation to the main setting (except Process value alarm).

[When the alarm action is set as energized]

When the input exceeds the range, the output turns ON or OFF
(in the case of High/Low limit range alarm).

[When the alarm action is set as deenergized]

The output acts conversely.

- Setting accuracy

Thermocouple : Within $\pm 0.3\%$ of input full scale ± 1 digit, or $\pm 2^\circ\text{C}$ (4°F) whichever is greater

RTD : Within $\pm 0.2\%$ of input full scale ± 1 digit

- Action : ON/OFF action
Hysteresis, 0.1 to 100.0 $^\circ\text{C}$ ($^\circ\text{F}$)

- Output : Open collector
Control capacity, 24Vdc 0.1A (maximum)

Loop break alarm output

When manipulating value is in its maximum or minimum status, the alarm is activated if the process variable does not change at a rate higher than the setting span within the setting time.

Detects Heater burnout, Sensor burnout and Abnormality at operation end.

Output: Open collector

Control capacity, 24Vdc 0.1A (maximum)

Control action

PID action (with auto-tuning function)

PD action (with auto-reset function) (When I value is set to 0.)

P action (with auto-reset function) (When I and D values are set to 0.)

ON/OFF action (When P value is set to 0 or 0.0.)

Proportional band: 0 (0.0) to rated scale maximum value

Integral time : 0 to 3600s (off when set to 0)

Derivative time : 0 to 3600s (off when set to 0)

Proportional cycle: 1 to 120s

ARW : Automatic

Output limit : 0 to 100% (For the Current output type, -5 to 105%)

Hysteresis : 0.1 to 100.0 $^\circ\text{C}$ ($^\circ\text{F}$)

Circuit insulation configuration

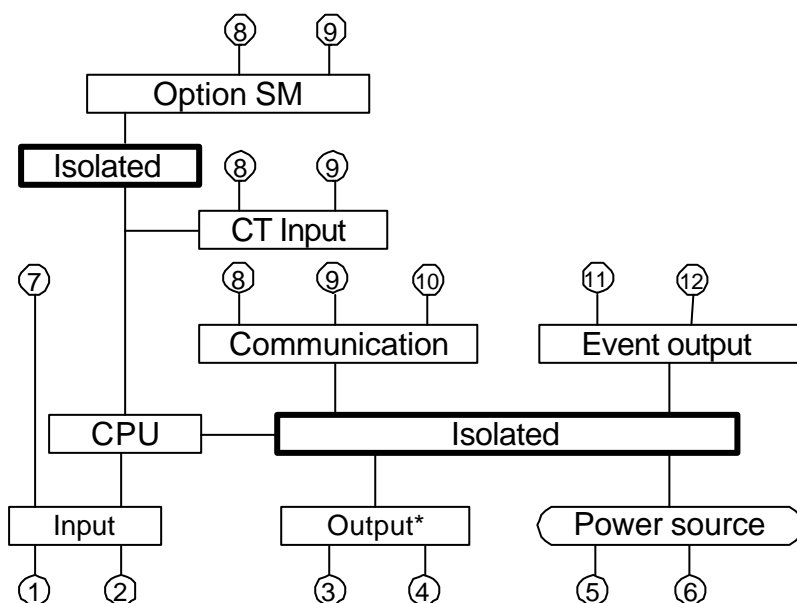

* If the control output type is current or non-contact voltage output, between the communication and output is non-isolated.

Insulation resistance

10MΩ or greater at 500Vdc

In the case of the above Circuit insulation configuration (*), because the communication and output terminals are not isolated from one another, the insulation resistance test must not be carried out.

Dielectric strength

Between input terminal and ground -----1.5kVac for 1 minute

Between input terminal and power terminal ----- 1.5kVac for 1 minute

Between power terminal and ground -----1.5kVac for 1 minute

Between output terminal and ground -----1.5kVac for 1 minute

Between output terminal and power terminal -----1.5kVac for 1 minute

Power consumption: Approx. 5VA

Ambient temperature: 0 to 50°C (32 to 122°F)

Ambient humidity : 35 to 85%RH (non-condensing)

Weight : Approx. 100g

External dimension : 48 x 24 x 98.5mm (W x H x D)

Material : Base and case, Flame resisting resin

Color : Base and case, Light gray

Attached functions : Power failure compensating function
 Self-diagnostic function
 Automatic cold junction temperature compensating function
 Input burnout indicating function (upscale, downscale)

Accessories : Mounting frame -----1 piece
 Instruction manual ----- 1 copy
 Terminal cover -----1 piece [When option TC is applied.]
 Current transformer-----1 piece
 CTL-6-S [When option W(5A, 10A, 20A) is applied.]
 CTL-12-S36-10L1 [When option W(50A) is applied.]

8.2 Optional functions**Serial communication [Option code: C5]**

When this option is applied, setting of the items; Temperature alarm, Heater burnout alarm and Loop break alarm can be performed by serial communication. However, as to the Event output, the item selected in Event output function selection has priority.

The option [C5] cannot be applied to the FCL-130.

When the option [SM] or [W] is applied, the option [C5] cannot be applied together.

Following operations can be performed by the external computer.

- (1) Reading and setting of the Main setting value, PID values and others
- (2) Reading of input value and action status
- (3) Change of the function

Communication circuit : Based on EIA RS-485 [Option: C5]

Communication method : Half-duplex communication start-stop synchronous

Transfer rate : 2400, 4800, 9600 and 19200bps (selectable by key operation)

Data format : Start bit 1
 Data bit 7
 Parity Even parity
 Stop bit 1

Heater burnout alarm [Option code: W]

Watches the heater current with CT (current transformer), and detects the burnout.

This option cannot be applied to the type current output.

The option [C5] cannot be applied to the FCL-130.

When the option [SM] or [C5] is applied, the option [W] cannot be applied together.

Rating : 5A [Option W(5A)], 10A [Option W(10A)],
 20A [Option W(20A)] or 50A [Option W(50A)]

Setting range : In the case of 5A, 0.0 to 5.0A (off when set to 0.0)
 In the case of 10A, 0.0 to 10.0A (off when set to 0.0)
 In the case of 20A, 0.0 to 20.0A (off when set to 0.0)
 In the case of 50A, 0.0 to 50.0A (off when set to 0.0)

Setting accuracy: $\pm 5\%$
 Input resolution : 1/200 of each rated value
 Action : ON/OFF action
 Output : Open collector
 Control capacity, 24Vdc 0.1A (maximum)

Setting value memory (external selection) [Option code: SM]

If this option is applied, the main setting value 1 or 2 can be changed by the external contact.
 The option [SM] cannot be applied to the FCL-130.
 When the option [W] or [C5] is applied, the option [SM] cannot be added together.
 When the contact open : Main setting 1
 When the contact closed: Main setting 2

Color black [Option code: BK]

Front panel : Dark gray
 Base and case: Black

Terminal cover [Option code: TC]

Electrical shock protecting terminal cover

Designated specifications

Range : Shipped as designated range.
 Temperature alarm action: Shipped as designated temperature alarm action.
 Event output : Shipped as designated event output.
 Control action : Shipped as designated PD, ON/OFF or cooling action.
 Hysteresis : Shipped as designated hysteresis.
 Initial value : Shipped as designated Initial value.





9. Troubleshooting

When troubled, refer to the following items after checking the power and the wiring.

<Indication>

Phenomenon	Presumed cause and the action
If PV/SV display is indicating [OFF]	<ul style="list-style-type: none"> Control output OFF function is working. → Press the  key for approx. 1s to release the function.
If [----] is blinking on the PV/SV display	<ul style="list-style-type: none"> Thermocouple or RTD is burnt out. [In the case of Thermocouple] If the input terminal of the instrument is connected, and if nearby room temperature is indicated, the instrument should be normal and sensor may be burnt out. [In the case of RTD] If approx. 100Ω of resistance is connected to the input terminal between A-B of the instrument and between B-B is connected, and if nearby 0°C (32°F) is indicated, the instrument should be normal and sensor may be burnt out. Lead wire of thermocouple or RTD is not surely mounted to the instrument terminal.
If [- - - -] is blinking on the PV/SV display	<ul style="list-style-type: none"> Polarity of thermocouple or compensating lead wire is reverse. Codes (A, B, B) of RTD does not agree with the instrument terminal.
If indication of PV/SV display is abnormal or unstable.	<ul style="list-style-type: none"> Designation of the Sensor input is improper. Temperature unit (°C or °F) is mistaken. Sensor correcting value is unsuitable. → Set the value suitably. Specification of the Thermocouple or RTD is improper. AC leaks into thermocouple or RTD circuit. There is a piece of equipment to send out inductive interference or noise near the controller.

<Key operation>

Phenomenon	Presumed cause and the action
If it is impossible to set. If the value does not change by the  ,  keys.	<ul style="list-style-type: none"> • Setting value lock (mode 1 or 2) is designated. → Release the lock designation. • During PID auto-tuning or auto-reset. → In the case of PID auto-tuning, cancel the tuning if necessary. In the case of Auto-reset, it takes approx. 4 minutes until the auto-reset is completed.
If the setting indication does not change in the rated scale range even if the  ,  keys are pressed, and setting is impossible.	<ul style="list-style-type: none"> • Main setting value high limit or low limit may be set at the point the value does not change. → Set it again by Auxiliary function setting mode 1.

<Control>

Phenomenon	Presumed cause and the action
If process variable (temperature) does not rise.	<ul style="list-style-type: none"> • Thermocouple or RTD is burnt out. • Lead wire of thermocouple or RTD is not securely mounted to the instrument terminal. • confirm the connection of the output is securely carried out.
If the main output remains ON status.	<ul style="list-style-type: none"> • Main output low limit setting value is set to 100% or greater in Auxiliary function setting mode 2. → Set the value properly.
If the main output remains OFF status.	<ul style="list-style-type: none"> • Main output high limit setting value is set to 0% or less in Auxiliary function setting mode 2. → Set the value properly.

If any unexplained malfunctions occur other than the above mentioned, make inquiries at our agency or the shop where you purchased the unit.

Shinko North America Ltd.

Reg. Office	: 25 Whitefriars Drive Toronto, Ontario, Canada M3A 2L2	
Mail Address	: 25 Whitefriars Drive Toronto, Ontario, Canada M3A 2L2	
URL	: http://www.shinkona.com	Tel: 416 444-0817
Toll Free	: 1 866-4SHINKO	Fax: 416 444-2361